

Rocker Panel**Special Tool(s) / General Equipment**

6.5 mm Drill Bit
Spherical Cutter
Self-Piercing Rivet (SPR) Remover/Installer
Belt Sander
Air Body Saw
MIG/MAG Welding Equipment
Locking Pliers

Materials

Name	Specification
Metal Bonding Adhesive TA-1, TA-1-B, 3M™ 08115, LORD Fusor® 108B	-
Seam Sealer TA-2-B, 3M™ 08308, LORD Fusor® 803DTM	-
Flexible Foam Repair 3M™ 08463, LORD Fusor® 121	-

Removal

NOTICE: Body side sectioning is prohibited within 50 mm of door hinge, door striker and restraints anchoring points.

NOTE: Aluminum body panels are highly receptive to heat transfer. With the extensive use of structural adhesives and non-structural sealers used in vehicle construction, the potential of heat transfer could impact adhesives and sealers in non-associated panels during the repair process. Many repairs areas that utilize structural adhesive may be separated after fastener removal by using a panel chisel along the joint/flange. Using heat not exceeding 425° F to loosen a bonded panel should only be done when **all panels in the joint** will be replaced and new adhesive applied.

NOTE: The rocker outer panel may be sectioned. The following assumes complete component replacement. Sectioning may be adjusted to meet repair requirement as long as door hinge, striker and restraints requirements are met.

NOTE: LH side shown, RH side similar.

1. Depower the **SRS**.
Refer to: [Supplemental Restraint System \(SRS\) Depowering](#) (501-20B Supplemental Restraint System, General Procedures).
2. Remove the front and rear door scuff plates and front and rear door opening weather strips.
3. Remove the front fender.
Refer to: [Fender](#) (501-02 Front End Body Panels, Removal and Installation).

4. Remove the front and rear doors.
Refer to: [Front Door](#) (501-03 Body Closures, Removal and Installation).
Refer to: [Rear Door](#) (501-03 Body Closures, Removal and Installation).
5. Remove the front and rear door lower hinges and striker.

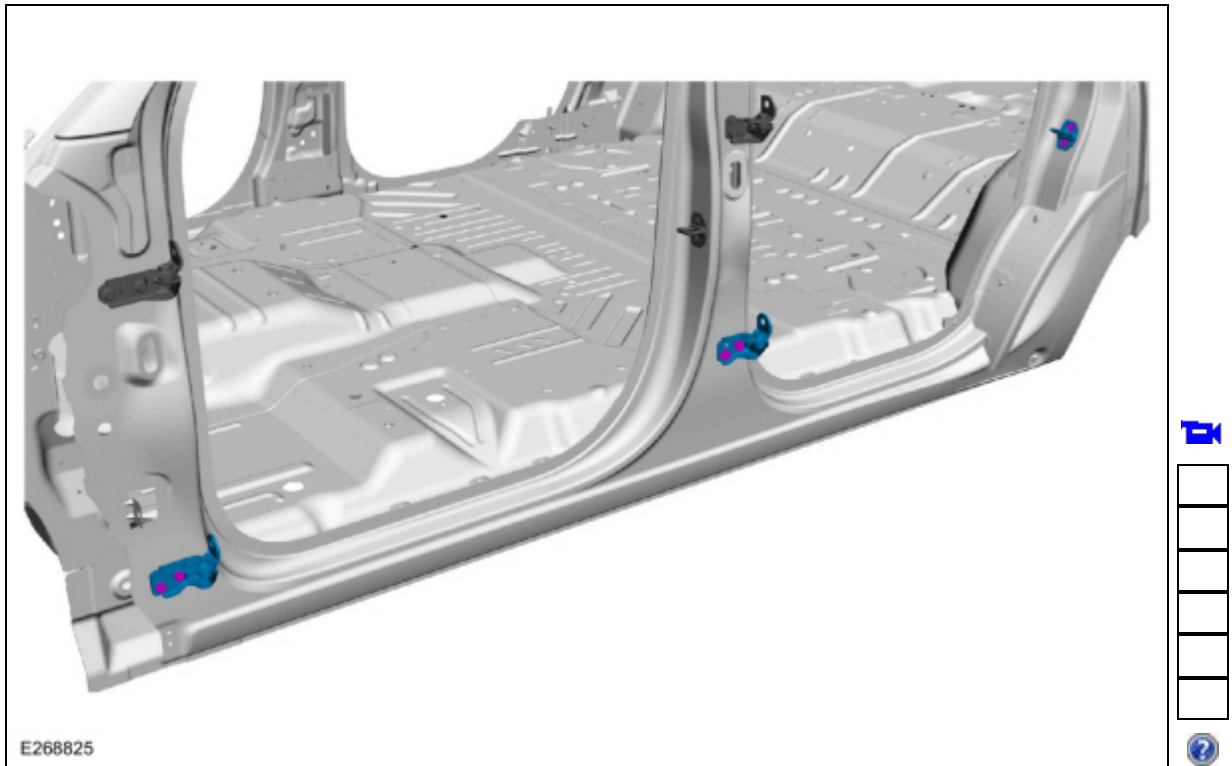

6. Verify the vehicle is dimensionally correct.
Refer to: [Body and Frame](#) (501-26 Body Repairs - Vehicle Specific Information and Tolerance Checks, Description and Operation).
7. Remove the quarter panel.
Refer to: [Quarter Panel](#) (501-30 Rear End Sheet Metal Repairs, Removal and Installation).
8. Carefully cut through the **outer panel only** as indicated.
Use the General Equipment: Air Body Saw
Use the General Equipment: Spherical Cutter

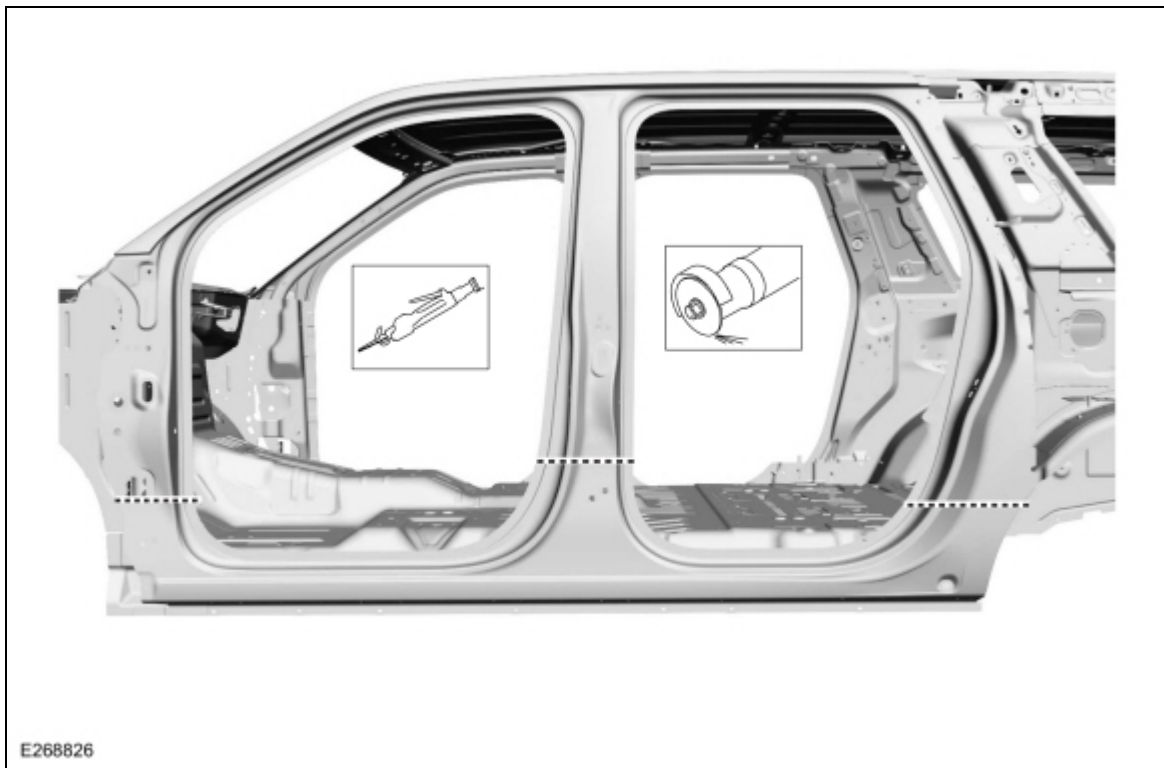

9. Remove the SPR fasteners and grind the lower wheelhouse flange.
 Use the General Equipment: Self-Piercing Rivet (SPR) Remover/Installer
 Use the General Equipment: Belt Sander
 Use the General Equipment: Spherical Cutter

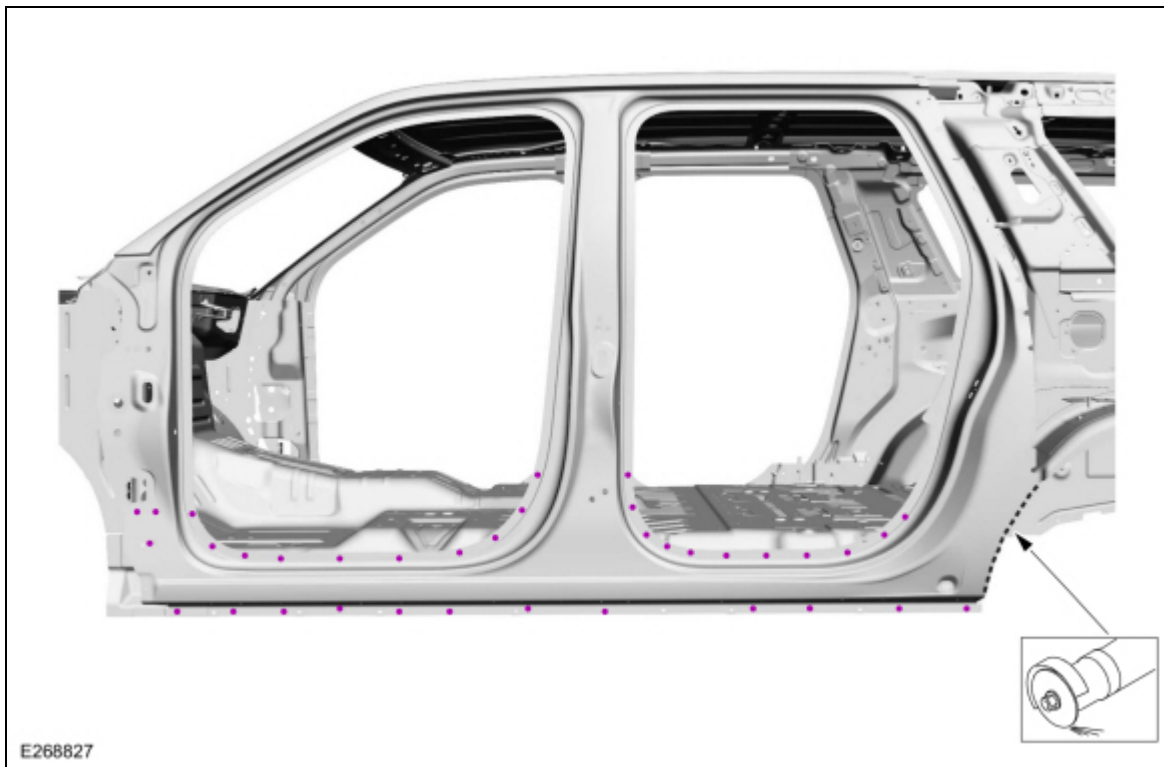

10. **NOTE:** Aluminum body panels are highly receptive to heat transfer. With the extensive use of structural adhesives and non-structural sealers used in vehicle construction, the potential of heat transfer could

impact adhesives and sealers in non-associated panels during the repair process. Many repairs areas that utilize structural adhesive may be separated after fastener removal by using a panel chisel along the joint/flange. Using heat not exceeding 425° F to loosen a bonded panel should only be done when **all panels in the joint** will be replaced and new adhesive applied.

NOTE: Pay particular attention to NVH foam and baffle locations to aid in assembly.

Break the adhesive bond and remove the rocker outer panel section.

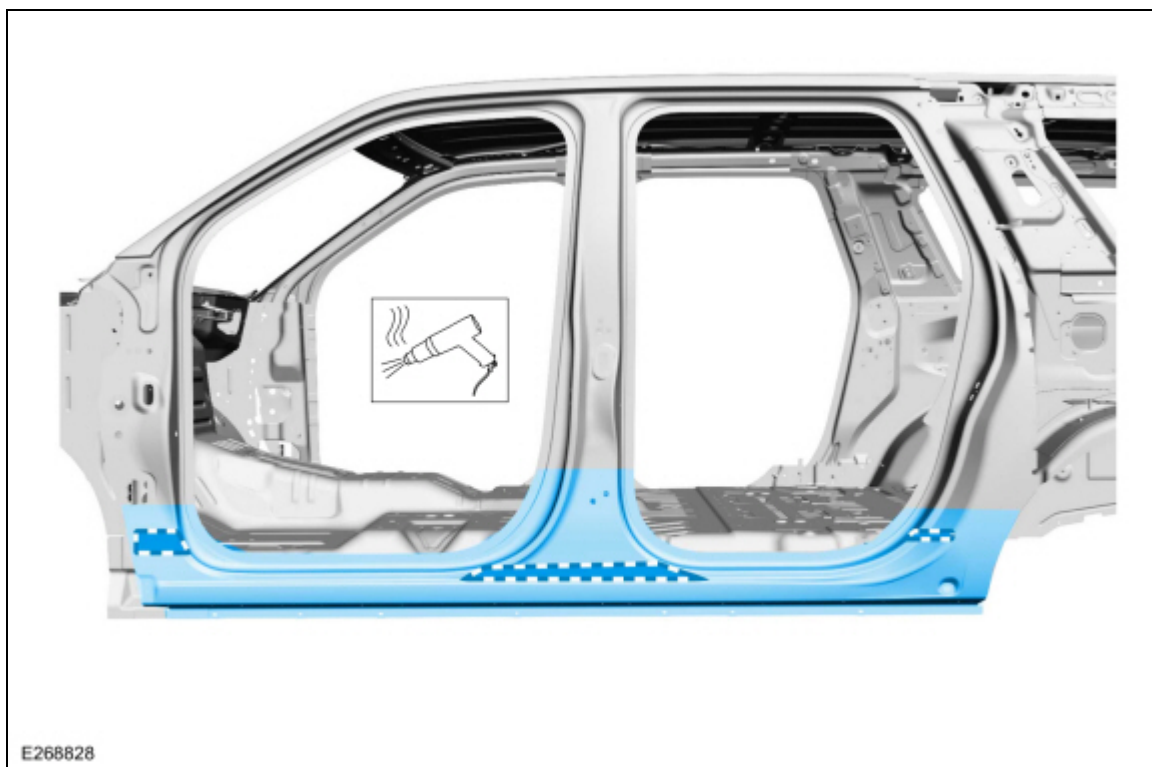

Installation

NOTICE: Body side sectioning is prohibited within 50 mm of door hinge, door striker and restraints anchoring points.

NOTE: SPR fasteners may not be placed directly over original SPR location. They must be placed adjacent to original location matching original quantity.

1. Cut a section from service panel to fit repair.
Use the General Equipment: Air Body Saw
Use the General Equipment: Spherical Cutter

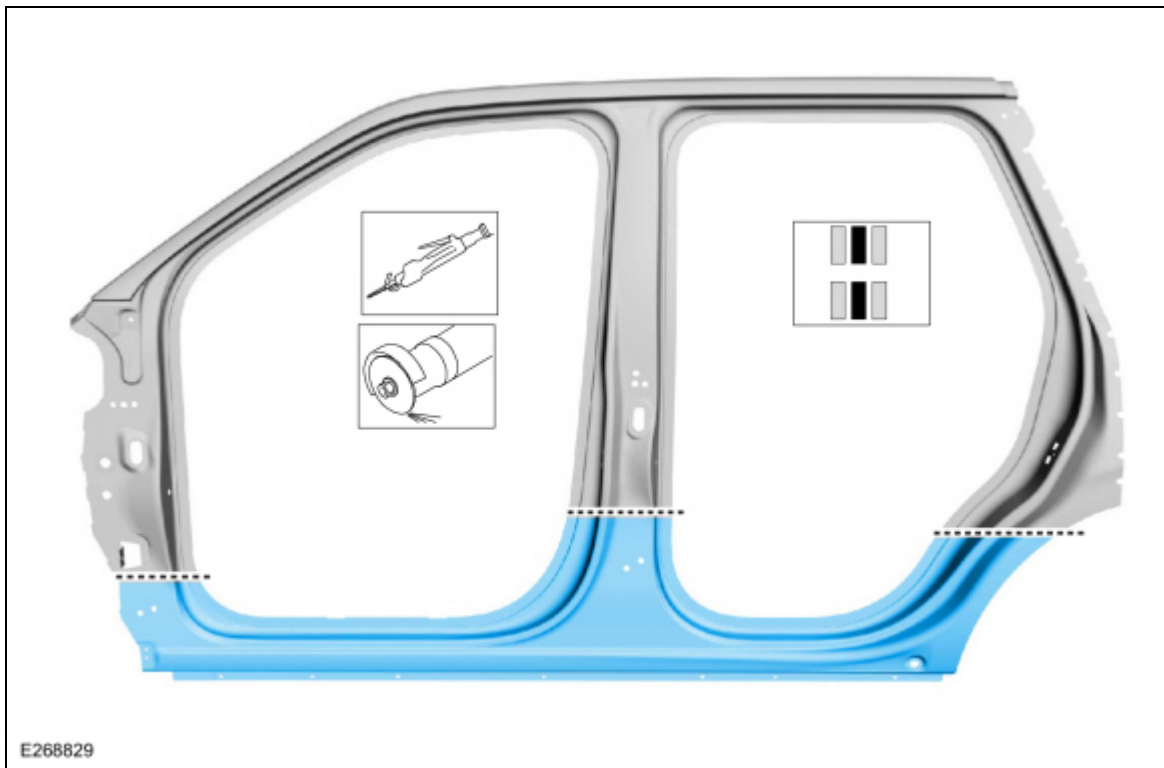

2. Sand using 80 grit sand paper to remove old adhesive and e-coat and clean.

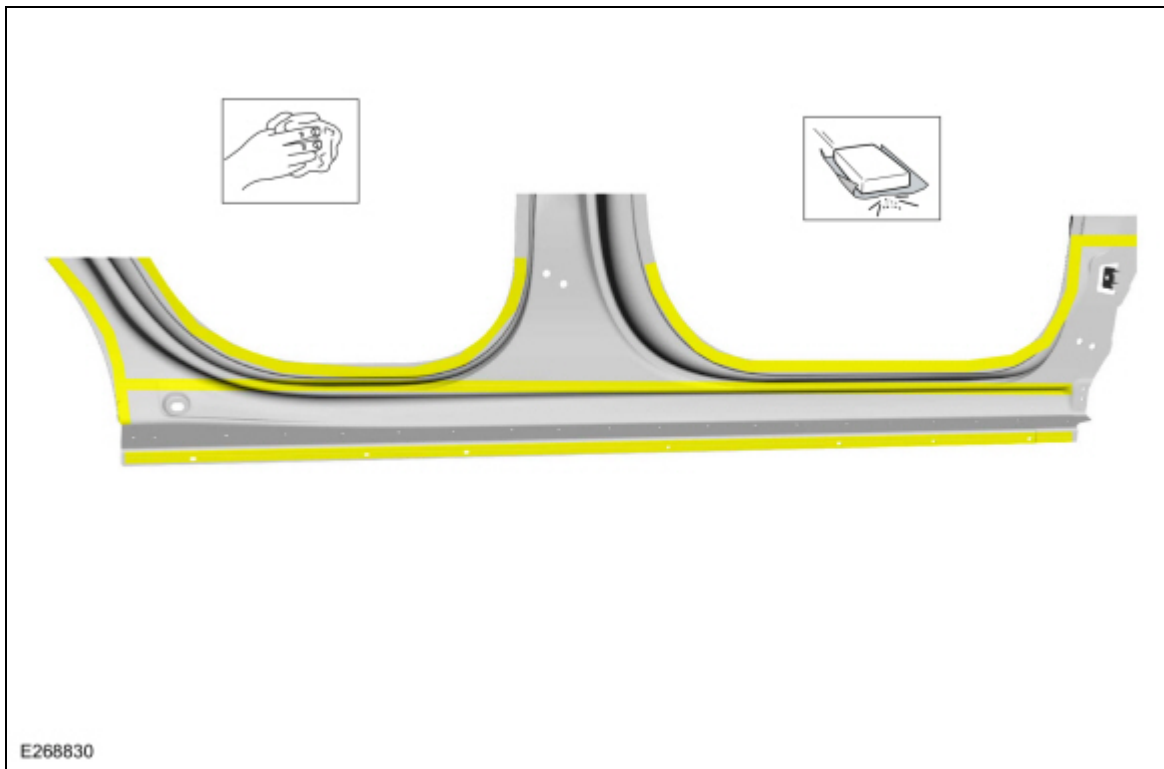

3. Sand using 80 grit sand paper to remove old adhesive and clean.

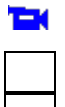
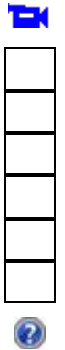

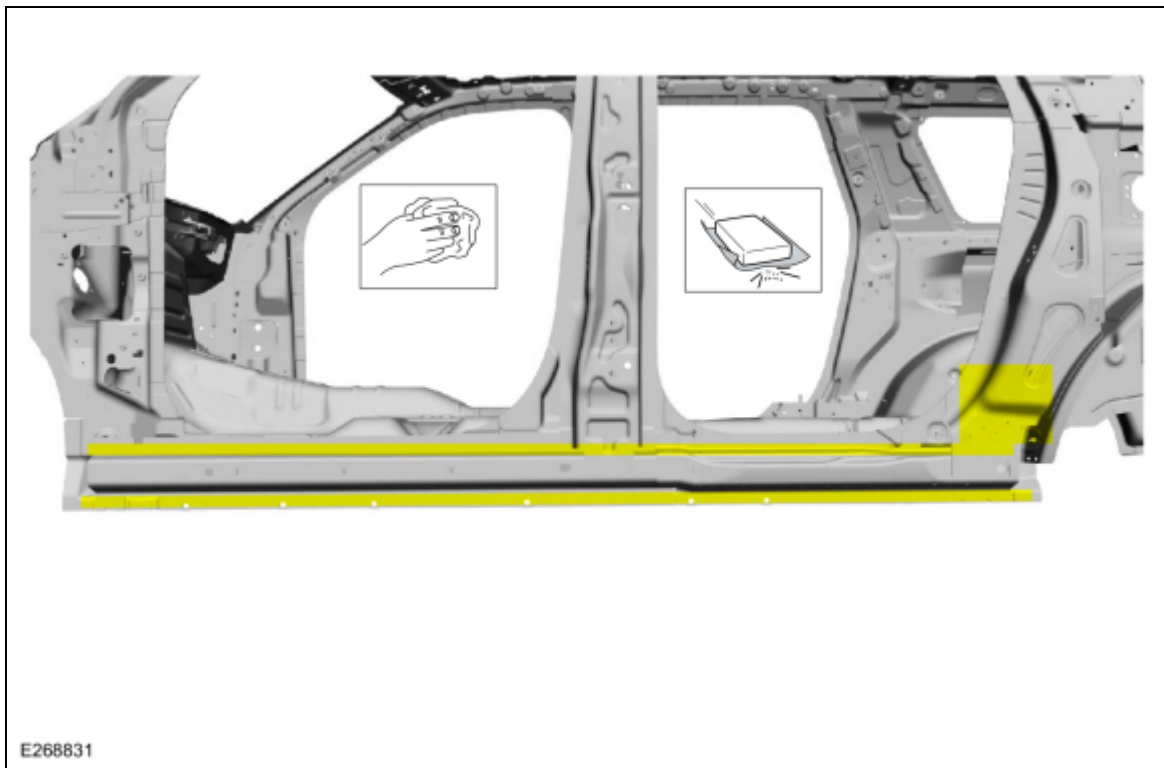

4. Apply adhesive and NVH foam to the mating surfaces as noted during removal.
Material: Flexible Foam Repair / 3M™ 08463, LORD Fusor® 121
Material: Metal Bonding Adhesive / TA-1, TA-1-B, 3M™ 08115, LORD Fusor® 108B

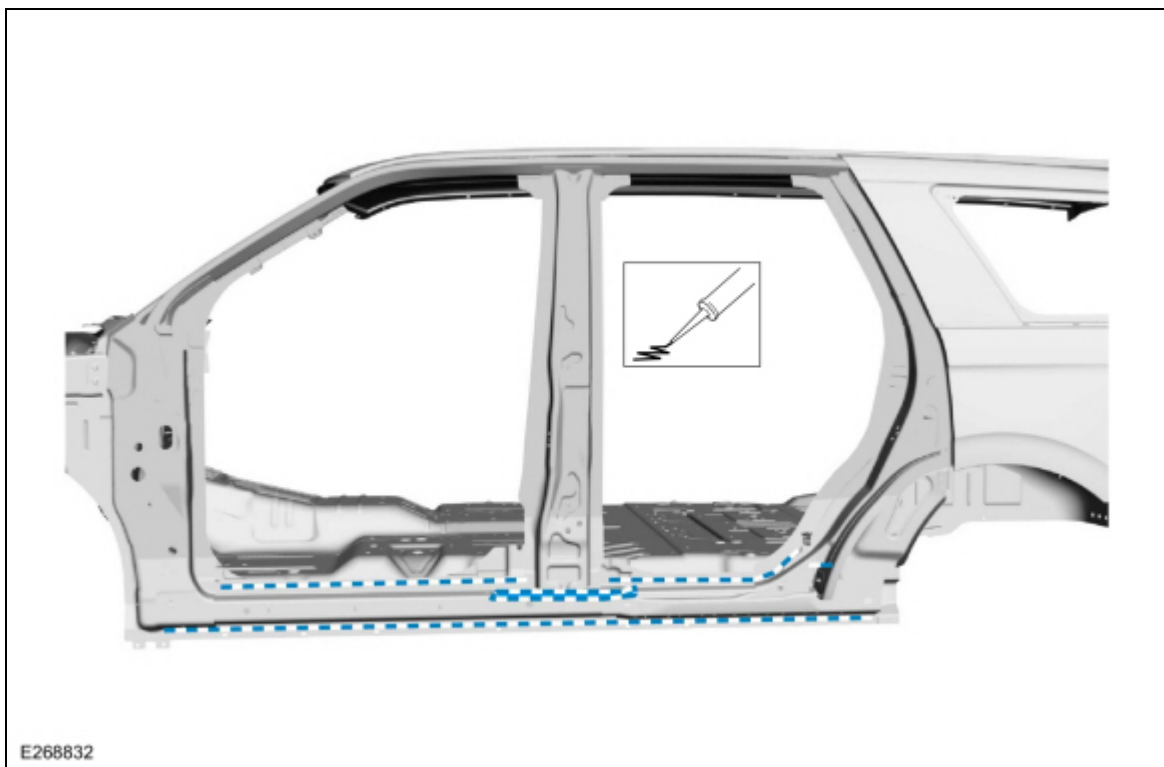

5. **NOTE:** *The use of a backer plate when creating butt weld joints will produce a stronger and more uniform repair.*

In butt-weld areas:

Create a backer plate from an unused portion of the old body panel or service replacement panel and install on the vehicle at each sectioning joint.

Refer to: [Joining Techniques](#) (501-25 Body Repairs - General Information, General Procedures).

- 6. Install the rocker panel and clamp in position.
Use the General Equipment: Locking Pliers

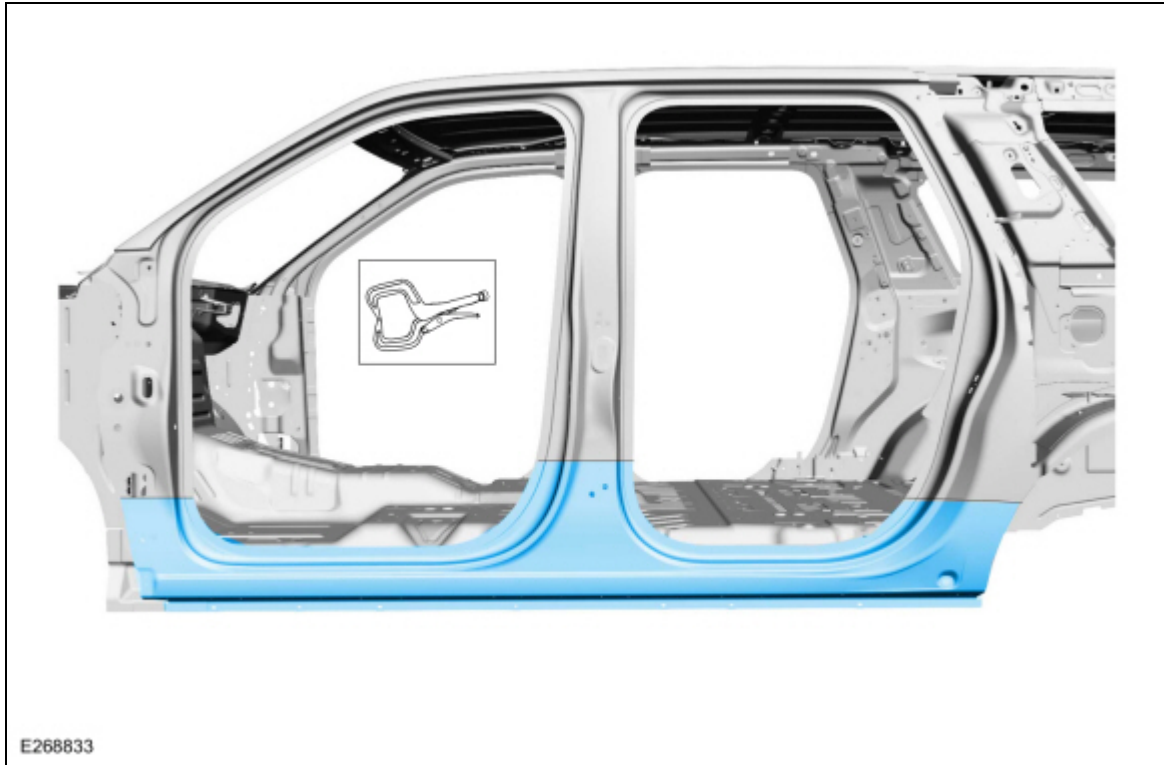

- 7. Drill for fasteners.
Use the General Equipment: 6.5 mm Drill Bit

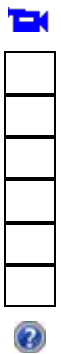

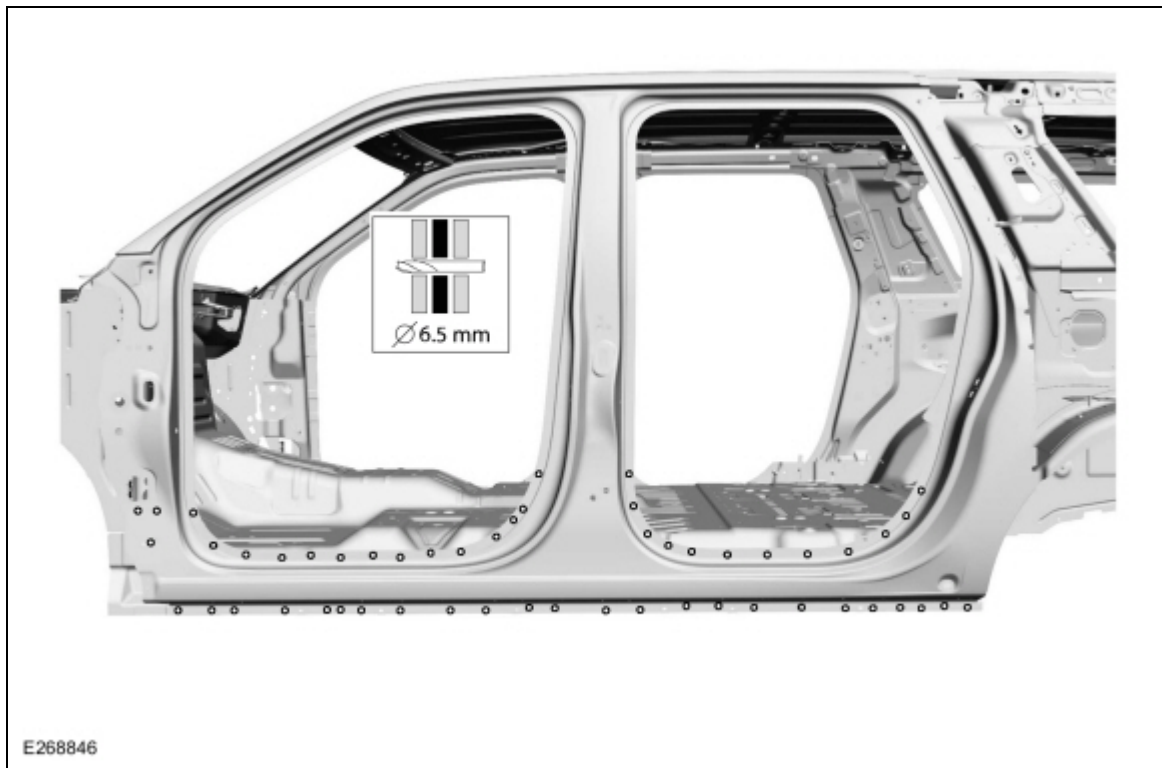

8. **NOTE:** *SPR fasteners may not be placed directly over original SPR location. They must be placed adjacent to original location matching original quantity.*

Install fasteners.

Item	SPR Number	SPR Code	Henrob® Mandrel	Pro-Spot® Mandrel	Blind Rivet	Solid Rivet	Rivnut®
1	W717752-S900	RB	DP10-200/H	SA-0400/SA-0402		W790377-S900	-
2	W717186-S900	EN	DP11-220/H	SA-0400/SA-0401	-	W790376-S900	-
3	W717188-S900	PW	DG10-200/H	SA-0400/SA-0402	-	W790376-S900	-
4	W708717-S900	AW	DP11-200/H	SA-0400/SA-0402	-	W790377-S900	-
5	W717186-S900	EN	DP11-200/H	SA-0400/SA-0402	-	W790377-S900	-
6	W717184-S900	QA	DP10-200/H	SA-0400/SA-0402	-	W790377-S900	-
7	W710246-S900	BN	DP10-200/H	SA-0400/SA-0402	-	W790377-S900	

Refer to: [Joining Techniques](#) (501-25 Body Repairs - General Information, General Procedures).
Use the General Equipment: Self-Piercing Rivet (SPR) Remover/Installer

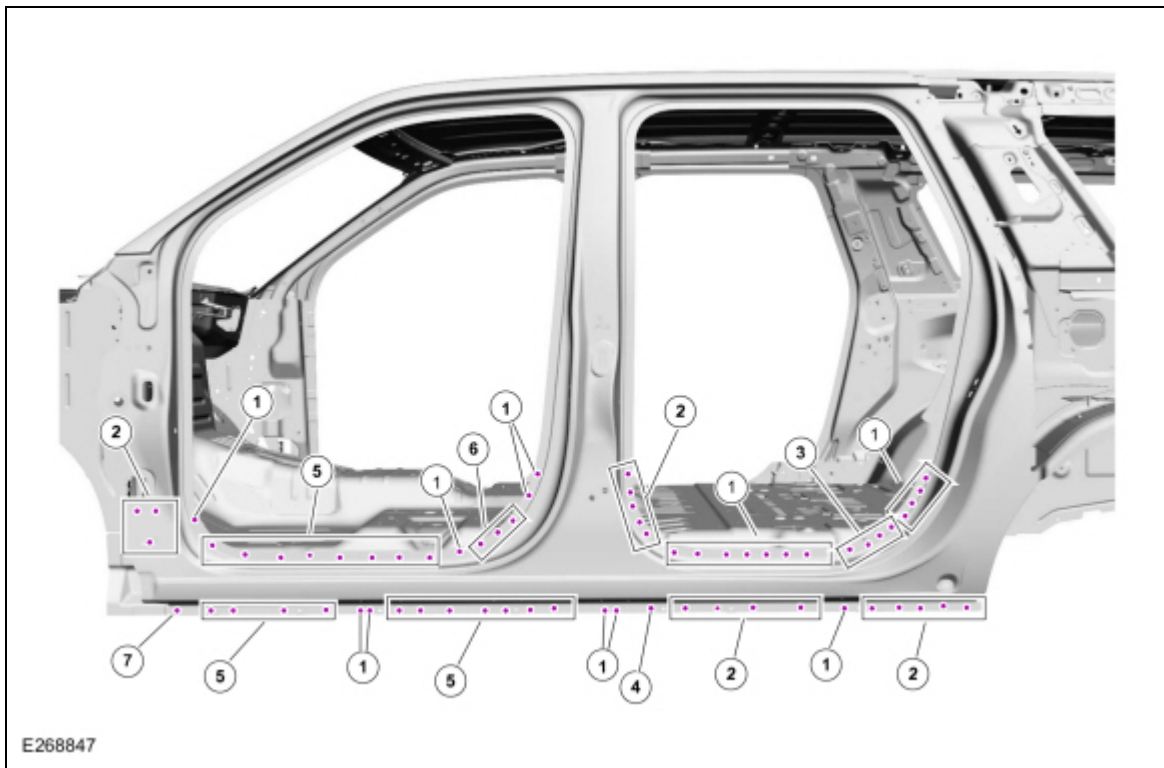

9. Complete joining of body side section to backing plates and seam weld at the sectioning joints. Refer to: [Joining Techniques](#) (501-25 Body Repairs - General Information, General Procedures). Use the General Equipment: MIG/MAG Welding Equipment

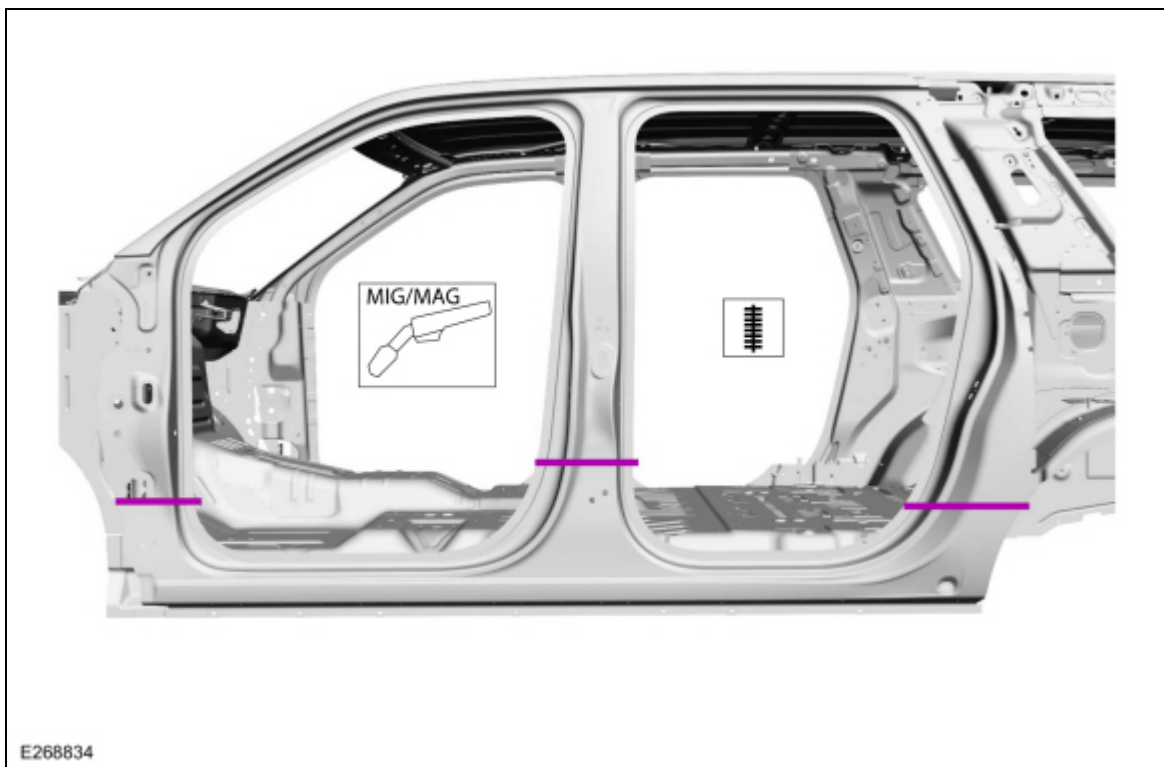

10. Metal finish the repair using typical aluminum metal finishing techniques and a fiber-based body filler. Refer to: [Special Repair Considerations for Aluminum Repairs](#) (501-25 Body Repairs - General Information, Description and Operation).

11. **Seam Sealing:**All areas must be sealed to production level.
Material: Seam Sealer / TA-2-B, 3M™ 08308, LORD Fusor® 803DTM
12. Install the quarter panel.
Refer to: [Quarter Panel](#) (501-30 Rear End Sheet Metal Repairs, Removal and Installation).
13. Refinish using a Ford approved paint system and typical refinishing techniques.
14. Install the front and rear door hinges and strikers.
 - Front door hinge.
Torque: 21 lb.ft (28 Nm)
 - Rear door hinge.
Torque: 22 lb.ft (30 Nm)
 - Door striker.
Torque: 18 lb.ft (25 Nm)

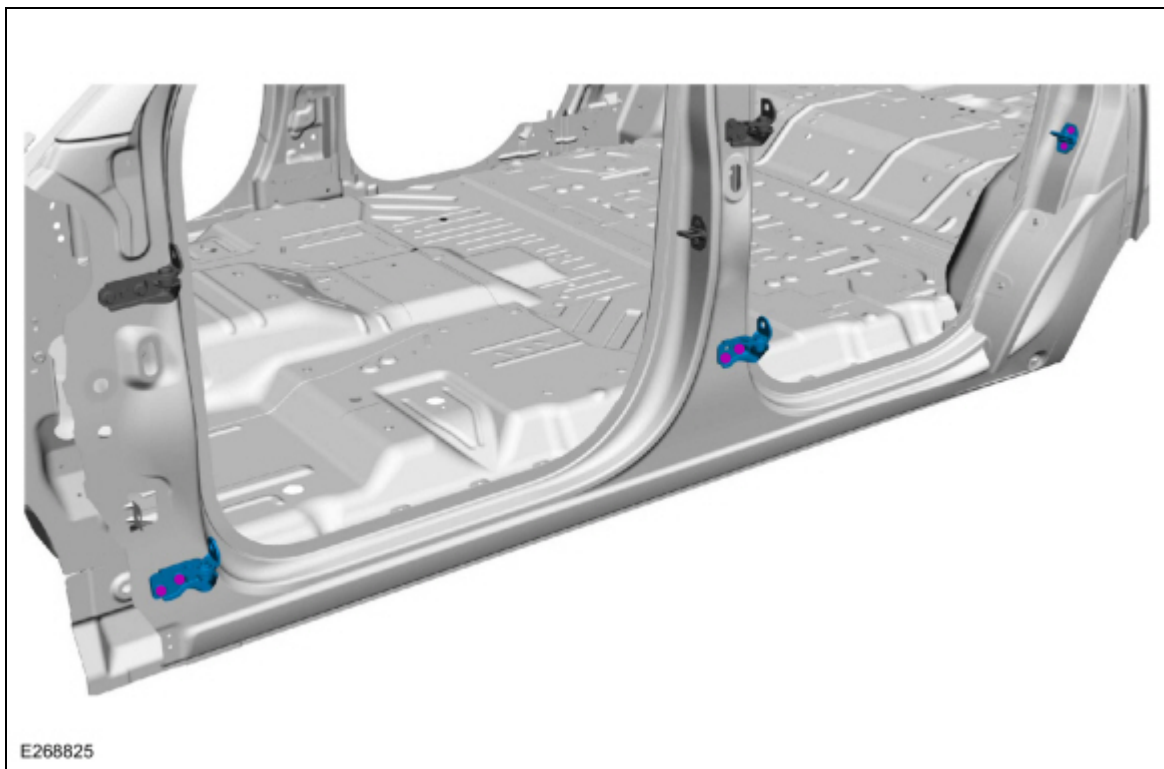

15. Install the front and rear doors.
Refer to: [Front Door](#) (501-03 Body Closures, Removal and Installation).
Refer to: [Rear Door](#) (501-03 Body Closures, Removal and Installation).
16. Install the front fender.
Refer to: [Fender](#) (501-02 Front End Body Panels, Removal and Installation).
17. Install the front and rear door scuff plates and front and rear door opening weather strips.
18. Align the front and rear doors.
Refer to: [Front Door Alignment](#) (501-03 Body Closures, General Procedures).
Refer to: [Rear Door Alignment](#) (501-03 Body Closures, General Procedures).

© Copyright 2021, Ford Motor Company.

